

REPLACEMENT CLASS "A" MIRROR HEAD INSTALLATION INSTRUCTIONS

NOTE: MIRROR HEAD CONFIGURATION MAY VARY.

WIRE COLOR	FUNCTION
YELLOW	COMMON
BLACK	VERTICAL
WHITE	HORIZONTAL

WIRE COLOR	FUNCTION
BROWN	COMMON
ORANGE	VERTICAL
BLUE	HORIZONTAL
RED	HEATER
GREEN	HEATER

INSTALLATION INSTRUCTIONS

TOOLS REQUIRED: 3/16" HEX WRENCH
WIRE CUTTERS
CRIMPING TOOL

MIRROR ASSEMBLIES WITH ELECTRICAL PLUG

- STEP #1 LOOSEN MIRROR HEAD SET SCREW.
STEP #2 LIFT MIRROR HEAD FROM MOUNTING BASE/ARM AND REMOVE OLD HEAD BY DISCONNECTING PLUGS. SAVE PIVOT CLAMP TO ATTACH REPLACEMENT HEAD. (SEE VIEW A-A)
STEP #3 TO MOUNT THE REPLACEMENT MIRROR HEAD. CONNECT THE MALE MIRROR HEAD PLUGS TO THE FEMALE PLUGS ON THE MOUNTING BASE/ARM. (MAKE SURE THE PLUGS ARE ATTACHED PROPERLY BY MATCHING THE WIRE COLORS ON THE MIRROR HEAD TO THE WIRE COLORS ON THE MOUNTING BASE/ARM.) BE SURE TO PLACE CLAMP INTO MIRROR PIVOT POST PRIOR TO POSITIONING MIRROR PIVOT INTO BASE/ARM SEE (VIEW A-A.)
STEP #4 PIVOT MIRROR HEAD INTO PROPER VIEWING POSITION AND TIGHTEN SET SCREW.

MIRROR ASSEMBLIES WITHOUT ELECTRICAL PLUG

- STEP #1 LOOSEN MIRROR HEAD SET SCREW.
STEP #2 LIFT MIRROR HEAD FROM MOUNTING BASE/ARM AND REMOVE OLD HEAD BY CUTTING MIRROR HEAD WIRES OFF AS CLOSE TO MIRROR HEAD AS POSSIBLE. SAVE PIVOT CLAMP TO ATTACH REPLACEMENT HEAD. (SEE VIEW A-A)
STEP #3 CUT PLUGS OFF REPLACEMENT MIRROR HEAD LEAVING AS MUCH WIRE AS POSSIBLE.
STEP #4 ON BOTH THE REPLACEMENT MIRROR HEAD AND EXISTING MOUNTING BASE/ARM CUT OUTSIDE WIRE JACKET BACK APPROXIMATELY 2-1/2" AND 3-1/2" AS SHOWN. STRIP INDIVIDUAL WIRES BACK 1/4" (SEE VIEW B-B)
STEP #5 CONNECT REPLACEMENT MIRROR HEAD WIRES TO EXISTING MOUNTING BASE/ARM WIRES USING BUTT CONNECTORS SUPPLIED WITH KIT MATCH WIRE COLORS IN REPLACEMENT MIRROR HEAD WITH WIRES IN MOUNTING BASE/ARM AS SHOWN IN VIEW B-B. PULL ON WIRE CONNECTIONS TO MAKE SURE BUTT CONNECTORS ARE CRIMPED PROPERLY.
STEP #6 POSITION MIRROR HEAD INTO MOUNTING BASE/ARM. BE SURE TO PLACE CLAMP INTO MIRROR PIVOT POST PRIOR TO POSITIONING MIRROR PIVOT INTO BASE/ARM AS SHOWN IN VIEW A-A.
STEP #7 PIVOT MIRROR HEAD INTO PROPER VIEWING POSITION AND TIGHTEN SET SCREW.

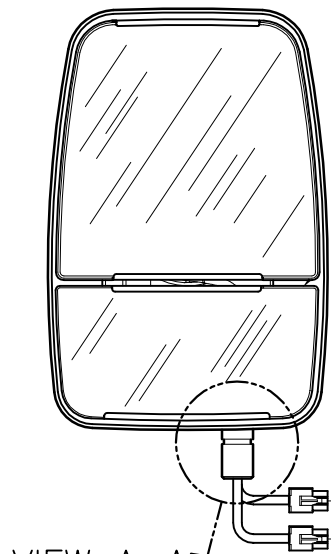

VIEW A-A

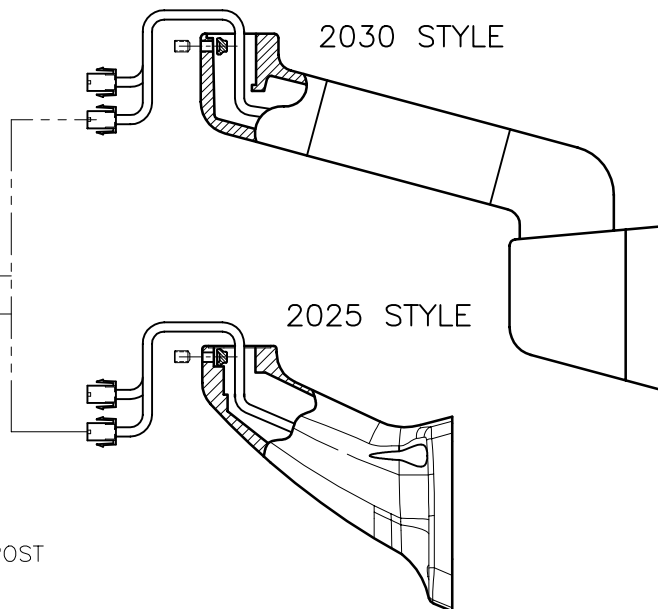
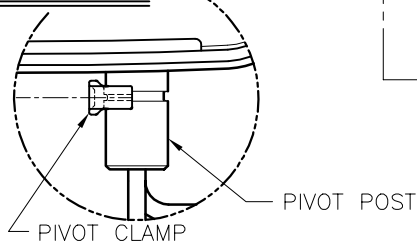

VIEW B-B

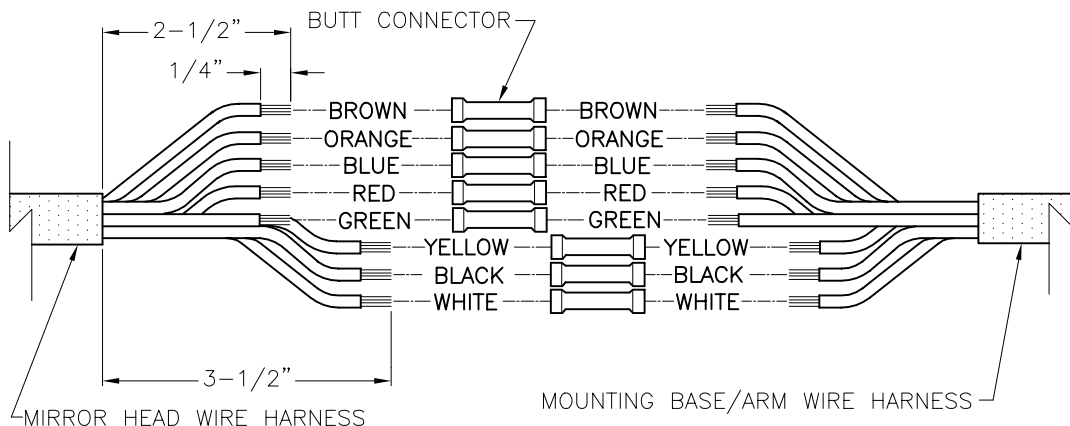

FUNCTIONAL REVISIONS:
ALL REVISIONS WITH SOLID
TRIANGLE ARE USABLE

REVISIONS
ECN #E01044
▲01 02-01-01 MS

VELVAC DRAWN BY: MS
DATE: 02-01-01

INSTALLATION INST. FOR REPLACEMENT
CLASS "A" HEATED REMOTE FLAT/HEATED
REMOTE CONVEX MIRROR HEAD

PROPRIETARY

SCALE:

THIS CONCEPT & DRAWING IS THE
PROPERTY OF VELVAC, INC. AND
SHALL NOT BE REPRODUCED,
COPIED, DISCLOSED, USED FOR THE
MANUFACTURE OR PROCUREMENT
FROM SOURCES OTHER THAN
VELVAC INC. WITHOUT WRITTEN
PERMISSION FROM VELVAC INC.

DRAWING NO.

7149842