

The Next Generation Hood Mount Mirror

# Mod Pod

## The Best Just Got Better!

We've taken our popular Mod Pod mirror system and added a lock down feature to the base for superior stability while continuing to provide for easy adjustments. To position the mirror, simply loosen the set screw with a 5/32" allen wrench, lift and rotate the mirror arm into proper viewing or foldback position then retighten the set screw. With the precision gears set at 12° intervals, small adjustments are held securely in place even before the lever clamps down on the arm leaving no cause for worry about the arm moving out of position while being tightened down.

The result is a perfect view every time!

This next generation Mod Pod continues to feature a corrosion resistant stainless steel bracket and mirror head along with a stylized chrome-plated mounting base for a long lasting, attractive appearance.

Mounting studs are factory assembled to the base for easier vehicle installations, and all complete kits include a premium quality mirror head, mounting gasket and two inner support straps.

### Mod Pod Mirror Head and Bracket Kits

#### Part No. Description

#### UNIVERSAL / ADJUSTABLE

- 714620** Includes Standard Convex Mirror
- 714621** Includes Wide View Convex Mirror
- 714622** Bracket Kit Only (no mirror head)

#### FIXED ARM LANE CHANGE

- 714623** Includes Standard Convex Mirror
- 714624** Includes Wide View Convex Mirror
- 714625** Bracket Kit Only (no mirror head)

#### FIXED ARM DUAL VIEW

- 714626** Includes Standard Convex Mirror – Right Side
- 714627** Includes Standard Convex Mirror – Left Side
- 714628** Includes Wide View Convex Mirror – Right Side
- 714629** Includes Wide View Convex Mirror – Left Side
- 714630** Bracket Kit Only – Right Side (no mirror head)
- 714631** Bracket Kit Only – Left Side (no mirror head)



NEW 5/16" set screw helps hold mirror arm securely in place.

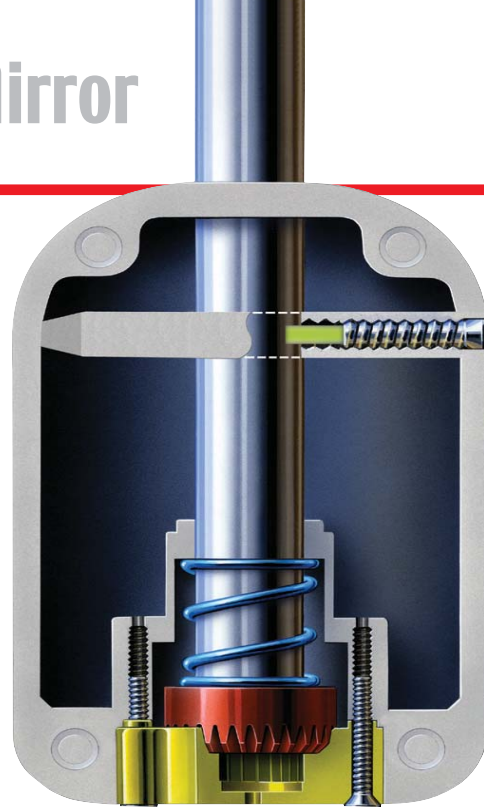

# VELVAC

Quality Driven Vehicle Components Since 1934

Velvac Incorporated • 2405 South Calhoun Road • New Berlin, Wisconsin 53151-2709 • www.velvac.com  
262.786.0700 • 800.783.8871 • Fax 262.786.4101 • sales@velvac.com



# VELVAC®

Quality Driven Vehicle Components Since 1934

## Introducing the Next Generation of Hood Mount Mirrors :

# Aero-Bell and Mod Pod

**CAUTION:**  
These mirrors have been radically modified with features and benefits to improve your truck's appearance and side vision capabilities.





# NEW Aero-Bell Mirror

## Its Features Speak for Themselves...

The latest styling concepts combine with non-corrosive materials to produce an innovative, new tripod mirror system built to last! Aerodynamically designed with chrome-plated, stylized, single-piece mounting "bells" and a molded clamping system, the new Velvac® Aero-Bell offers any truck a clean, refined appearance. Each mirror kit also includes mounting gaskets and stainless steel brackets, mirror head and hardware designed to resist rust and corrosion so the mirrors—and the truck—stay functional and attractive.

In addition to the standard adjustable tripod design, we also added solid arm mirrors designed specifically for the Freightliner FLD, Century Class and Columbia trucks. The elimination of adjustment hardware provides a cleaner, custom fit look while offering superior stability and a clear view of blind spot areas alongside the vehicle. These Aero-Bell mirror systems can be used for new installations through fleet specifications or as retrofits/replacements for original equipment mirrors. In addition to the Freightliner vehicles listed, they can also be used for a variety of other vehicle applications.



### The Newest Concept in

### Style and Function —

## Aero-Bell Mirror Head and Bracket Kits

Part No.	Description	Dimension A
715166	FIXED ARM—For Freightliner FLD	23.55"
715168	FIXED ARM—For Freightliner Century / Columbia	20.35"
715148	ADJUSTABLE—Short Tripod	17.5" to 24.5"
715150	ADJUSTABLE—Standard Tripod	27.9" to 33.9"

#### Replacement / Retrofit Kits:

- 748415 Bell Housing Kit—Includes Bell, Hardware and Hardware Caps
- 709661 Cap Kit—Includes 2 Snap-On Caps
- 748416 Clamp Kit—Includes Clamp and Hardware

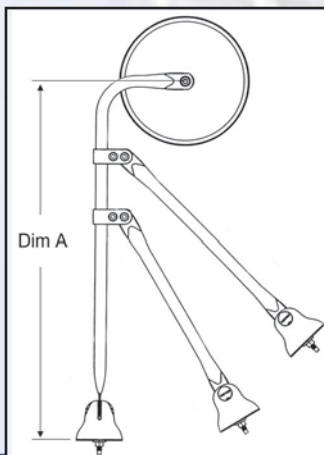

NEW OE-specific, fixed arm models available for a custom fit on Freightliner Columbia and Century Class trucks as well as the FLD.



8-1/2" mirror heads with 12" R.O.C. convex glass allow for an exceptional view alongside the vehicle and feature Velvac's own DuraBall® nylon ball joint system, so superior it is guaranteed for five years against cracking or breaking.



NEW chrome-plated ABS feet include chrome-plated caps to cover installation hardware giving the mirror a "finished" look while keeping dirt and other debris off internal parts.

*These components are chrome-plated to the same demanding specifications required by the largest truck manufacturers for a high quality, long-lasting finish.*



NEW non-corrosive nylon clamps adjust easily while adding a custom look and feel to any truck.

